



featuring **RISE** Technology 

Refer to PER-23-11 for building code compliance and product design values. The report can be downloaded from the following location: <https://risebuildingproducts.com/>

For all product installation questions, call customer service at (401) 490-4847. Be sure to use the latest version of installation instructions located at <https://www.risebuildingproducts.com/resources.html>

For detailed warranty information, refer to the substrate limited warranty at <https://www.risebuildingproducts.com/documents/RISE-Composite-Technologies-Substrate-Warranty-2022.pdf> and the paint limited warranty at <https://www.risebuildingproducts.com/documents/RISE-Composite-Technologies-Warranty-2022.pdf>

Install Rise Building Products consistent with the details in these instructions. Please contact customer service at the above number if you have any installation detail that is not covered in these instructions. These instructions supersede all other documents.

GENERAL PRACTICES:

1. **Store the products so they are flat, off the ground and protected from rain, dirt and other damaging conditions.** Unopened wholesale units of lap and trim stored in inventory may be stacked up to 6 units high. Do not stack panel siding more than 5 units high.
 - a. Product in storage or awaiting delivery should be stored under a roof, protective canopy, or shelter so it is protected from weather conditions that have the potential to damage the packaging and the product. **If the factory packaging is damaged, missing or removed; replace or repair the packaging promptly.**
 - b. Unopened units can be stacked up to 3 units high during transport by truck. Unload the siding/trim at the jobsite using a forklift. Rolling or dumping the product can damage the product and its factory primer or finish. Do not drag the siding/trim over itself or other surfaces. Take special precaution to preserve the quality of the factory coated surfaces.
 - c. Protect the product in storage or on the jobsite by keeping it thoroughly covered. This includes product that may be staged at different jobsite locations or on scaffolding overnight or during weather delays. **Keep the product dry and free from dirt and debris. It is important the product is dry during storage and installation to ensure paint adhesion, performance and avoid contamination.**
 - d. Avoid setting anything on the stored siding/trim to protect against damage to the finished surfaces. Do

not stack opened units.

2. Install the border trim prior to the siding. Use the trim to create separations at roof lines and product intersections, and borders around walls, windows, doors and other wall penetrations.

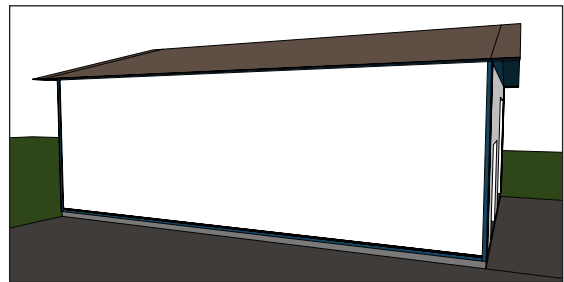

Figure 1 Wall bordered with trim

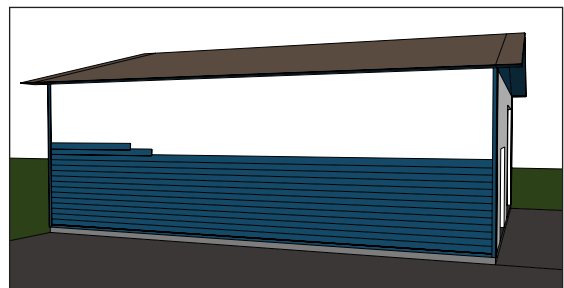

Figure 2 Lap siding in-fill

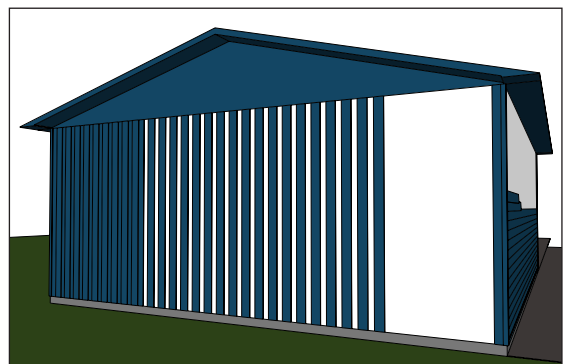

Figure 3 Board on board in-fill using vertically oriented lap siding

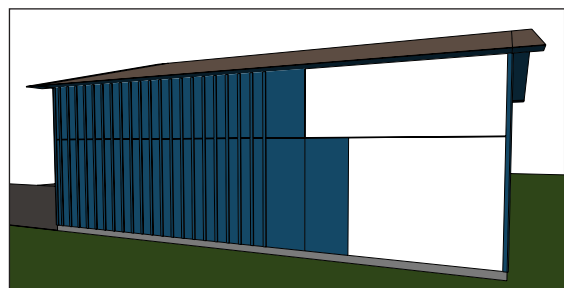

Figure 4 Board & Batten in-fill using panel siding and trim

3. Cut the siding and trim using the same tools normally used with wood. Use carbide tipped blades. Do not cut with damaged or dull tooling. Cut so the blade rotation is against the exterior face of the siding and trim.

Trim may be fastened using finish nails or brad nails. Box and common style nails are also suitable and more resistant to detachment. Please note that fastener performance and detachment is not covered under the terms of the limited warranty. Fasteners must be corrosion resistant in a manner that is suited to perform for the life of the trim. Note that smaller fasteners may require an increased number of fasteners per piece for secure attachment to the structure. Achieve 1" minimum embedment into wood and wood sheathing. Longer fasteners will increase embedment, withdrawal resistance, and attachment strength. Note that smaller diameter fasteners, such as 16-gauge nails, may bend more often at longer lengths. Pay close attention to the clipped ends and the packaging to determine if they are designed to create a hook at penetration. Set the gun pressure to rest the nail head flush with the surface of the trim. If common or box style fasteners are used, rest the head of the nail snug to the surface or flush with the surface. Do not over-drive or countersink the nails. Under driven fasteners can be hammer set using care to not damage the trim surface. Touch up nail heads discreetly with color matched paint. Carefully dab the exposed nail head. Avoid brushing or wiping over the nail heads. This can increase the visibility of the fasteners because of gloss and/or color variation.

Lap may be fastened with a box or common style nail having a minimum 0.092" diameter. Please refer to PER-23-11 to specify the correct fastener for your location's wind design requirement, application method, and assembly type. All fasteners must be corrosion resistant in a manner that is suited to perform for the life of the siding. Ensure consistent nail placement and embedment to maintain proper attachment and resist deflection or detachment due to fastener failure. Rest the head of the nail snugly on the surface of the siding. Nails may also be set flush with the surface but do not over drive or countersink nails.

4. Attach the trim and siding securely to the wall assembly according to these instructions and the specifications from your designer of record. Minimum fastener size and embedment must meet or exceed the requirements in PER-23-11. Do not exceed 16" OC framing spans unless you are fastening to a minimum 7/16" thick OSB or plywood sheathing. Do not exceed fastener spans greater than 16" OC for lap and 12" OC for panel siding. Consult your local code or authority for your prescribed wind zone. When installing over rigid foam sheathing, refer to table 2603.13.1 in the International Building Code or table R703.15.1 in the International Residential Code to determine the required fastener diameter, spacing and foam thickness limit. Increase the length of the fastener to ensure proper embedment as specified by these instructions and PER-23-11.

Cut the trim and siding safely with a clean, sharp blade suited for your equipment. In general, larger diameter blades tend to flex more during cutting. Blade flex can contribute to chipping or burning of the edge. Tooth count per blade can also influence the quality of the cut. Blades with more teeth may require a slower cut speed to achieve your desired quality of edge, cut quality, and installed aesthetic. You may want to consider a 7-1/4" blade with 24 carbide-tipped teeth to start with and then expand your blade options based on your individual needs. Use care to pick the blade or blades that provide consistent quality cuts and edges while also suiting your job conditions, productivity goals, and tools. Always cut the siding and trim so the rotation of the blade is cutting down against the exterior face of the product. Cutting in the opposite rotation will increase the chance of chipping along the cut edge.

5. For face nailing on smooth trim, please follow these tips for optimal aesthetics
 - Use a 16-gauge minimum headless finish nails or pin nails
 - Ensure finish nail is flush or slightly countersunk
 - o Slightly countersunk is an exception for trim fastening
 - o Ensure nails penetrate solid wood framing behind trim a minimum of 1 1/2"
 - Use high quality acrylic caulk or exterior wood filler for nail heads
 - o Light sanding or touch up may be required to match smooth surface of trim
 - If using primed material, paint trim along with siding
 - If using prefinished material, use touch up kits to paint filled in nail holes to match
 - Follow all other fastener, caulk and finishing guidelines
6. Flash as needed to release all incidental water from behind the siding. Incorporate the house-wrap (i.e. code approved water resistive barrier), flashing systems, and wall penetrations into a continuous integrated building envelope that protects against liquid water and air penetration into the wall assembly. Do not entrap moisture behind the siding or trim. All horizontal trim must be flashed with Z-flashing. Cover with inverted J-channel in areas where Z-flashing will not fit, such as sill trim applications.
7. For warranty coverage, RISE requires that all cut or ripped edges be treated with a minimum of one coat of oil-based primer whether the cut edge is exposed or not upon installation. Common brands of oil-based primer include KILZ Original interior/exterior oil based primed (black can) and ZINSSER® High Hide Cover-Stain® ALKYD available at most building material retailers. For exposed cut or ripped edges, RISE recommends one or more coat of oil-based primer with sufficient thickness to hide all exposed fibers. and 1 topcoat of 100% acrylic or latex paint that meet the paint manufacturers' requirements. For added performance, multiple layers of primer and/or paint can be applied.

LET'S GET STARTED:

Begin with the eave or cornice. Install the fascia and gable rake first to create a border for the roof and eave assemblies. Properly flash and cap parapet walls as instructed by the manufacturer of the metal coping system. Integrate the metal drip edge on sloped roofs with the roofing manufacturer's instructions. Utilize gutters and kick-out flashings to direct liquid water away from the structure.

Next, use Rise trim as soffit to finish the eave. Vent the soffit as required by your local code and your designer's specification.

Once the eave is complete, install the vertical trim to border the ends of the walls, wall penetrations, and terminations adjoining other exterior cladding materials or accents. Take the necessary time to consider any height variations or wall details that might affect the siding installation and final architectural finish. Install horizontal trim and frieze boards to complete the borders. Be sure to maintain transitions from wall to wall so the horizontal lines of the belly trim enable the lap siding to match evenly at corners. Properly flash horizontal materials so liquid water is able to drain from behind the siding to the exterior environment. Do not caulk or terminate drain points intended for moisture evacuation.

Fill in the area bordered by trim with Rise siding. Fasten and space the siding according to these instructions. Do not overdrive the fasteners. Expansion and contraction of building materials and building assemblies is natural. Space the siding and adjoining materials according to the details of these instructions. Failure to properly space material can cause undue stresses on the structure and its components resulting in unwanted consequences.

Flash all openings, penetrations, and other areas where water will collect or travel. All horizontal trim and transitions between materials must be flashed per these instructions and the flashing manufacturer's instructions. Do not caulk or dam water at drainage points.

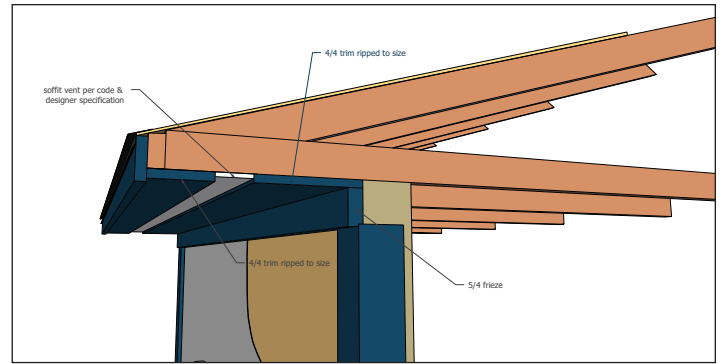
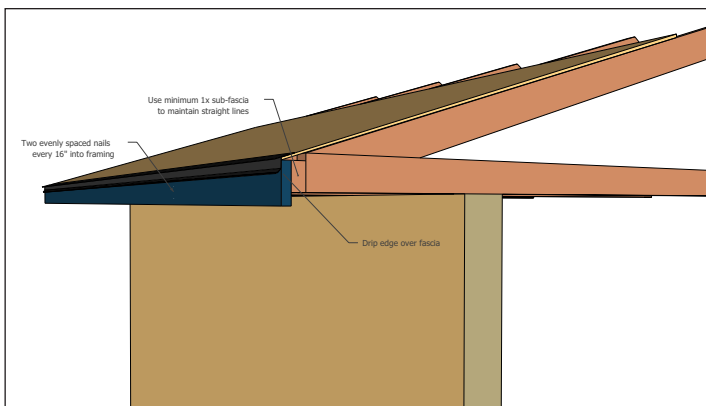

Install a starter strip before installing lap siding. Maintain 3/8" clearance between strip and horizontal flashing. The starter strip can be ripped from the Rise lap siding. Wood, pvc and other materials can also be used. The thickness of the starter strip should be equal to the thickness of the lap siding.

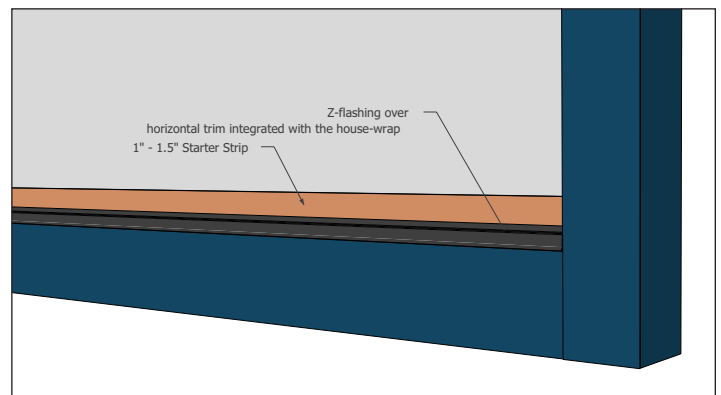

Caulk according to these instructions using a minimum class 25 ASTM C920 sealant. RISE has been color matched for both the OSI and DAP caulk products. See Paint & Caulk Color Match Chart for details.

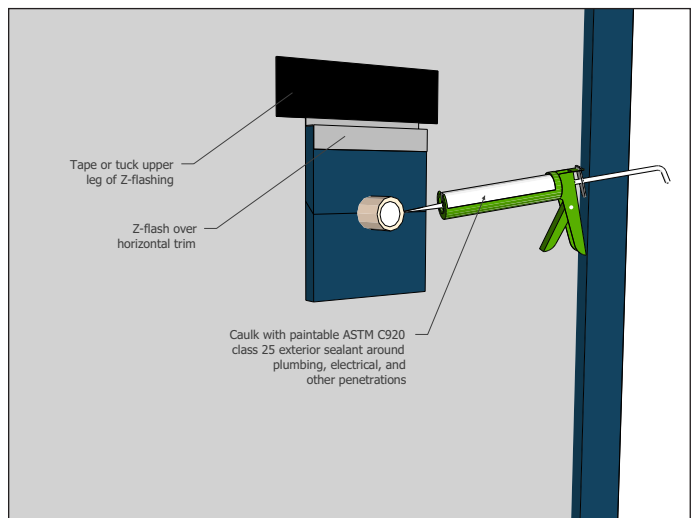

Install house-wrap or combined panel/barrier systems according to their respective manufacturer's instructions and the local code. Apply all flashings and wall penetrations to create a continuous building envelope to resist water and air penetration.

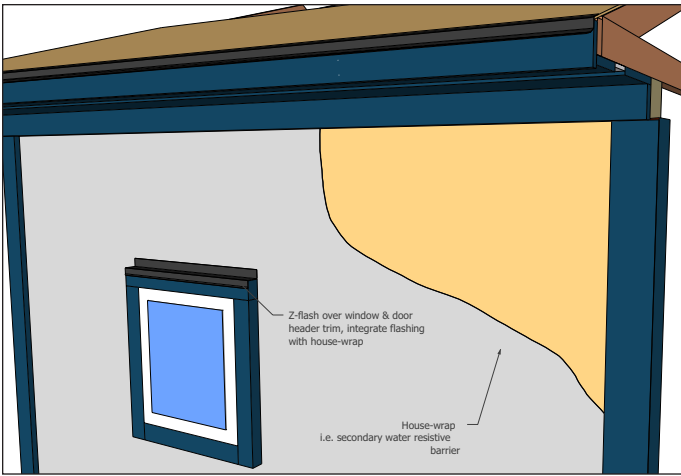

Overlap siding 1-1/4" or more. Conceal the fasteners in in the lap joint. Place the fasteners a minimum of 1" from the top edge to maintain a tight lap joint between courses. Do not rip the siding for smaller reveals. Increase the overlap and build out the trim so remains proud of the siding.

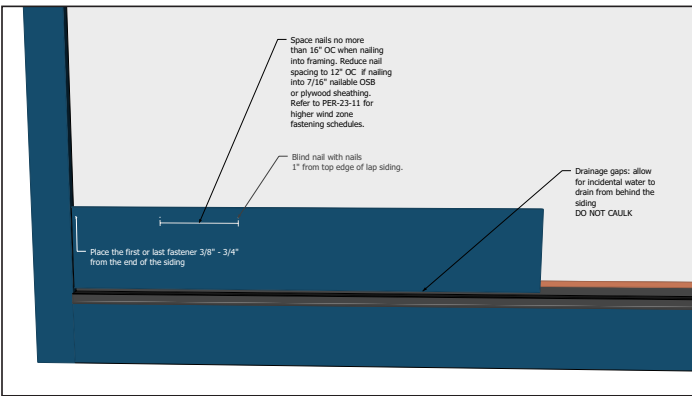

Maintain a 3/8" drainage gap over horizontal wall flashings to direct water to the exterior. Dam the ends of the horizontal flashing with sealant to direct water to the exterior. Never caulk the full length over horizontal wall flashing. Do not entrap water behind the siding.

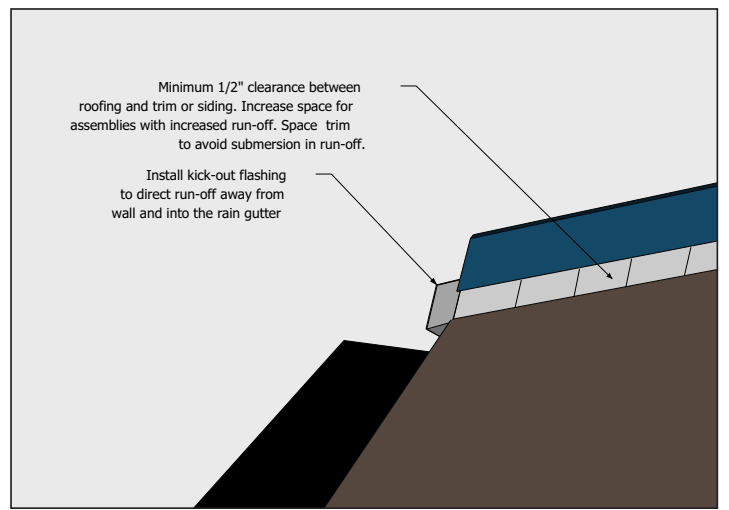
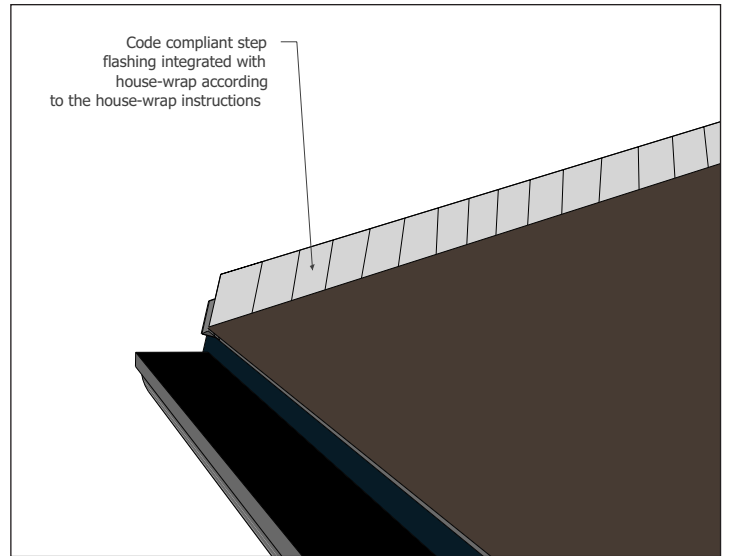
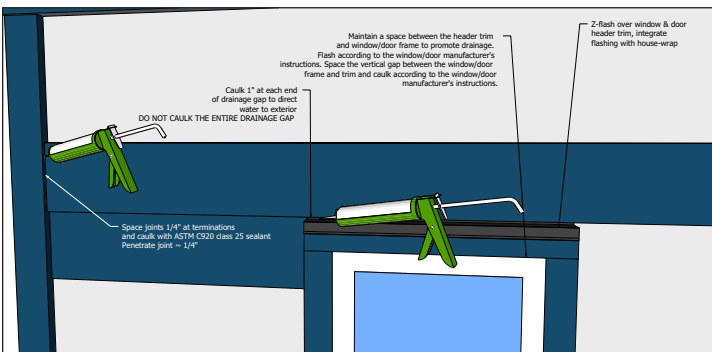

Securely attach all Rise products per these instructions. Do not place fasteners less than 3/8 inch from any end of trim or lap and edge of panel. Refer to PER-23-11 for additional fastening requirements to meet various wind zone requirements.

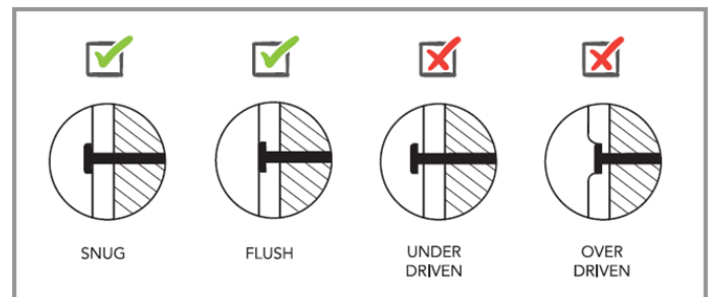

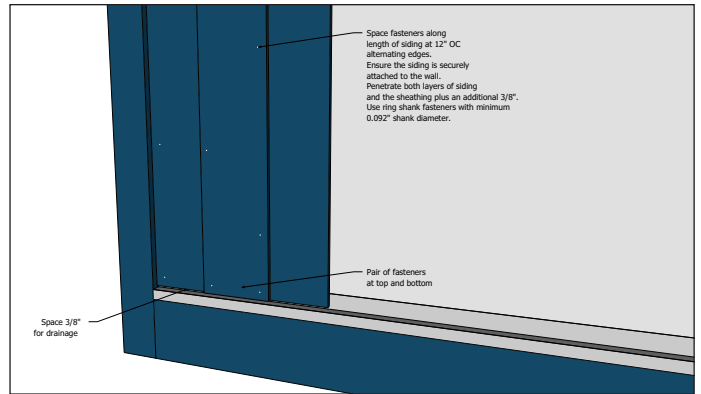
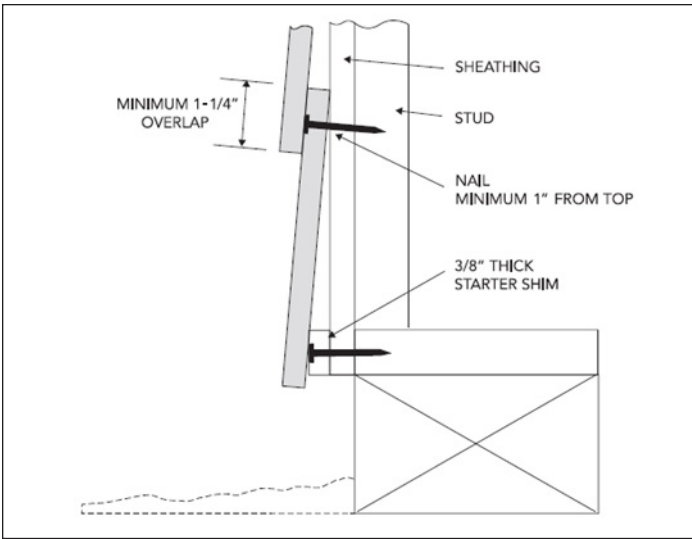

When bridging floor assemblies, fasten trim and vertical lap siding with a minimum of two fasteners in the upper portion of the rim board and another pair of fasteners into the lower portion of the rim board. Avoid fastening into the bottom or top plates.

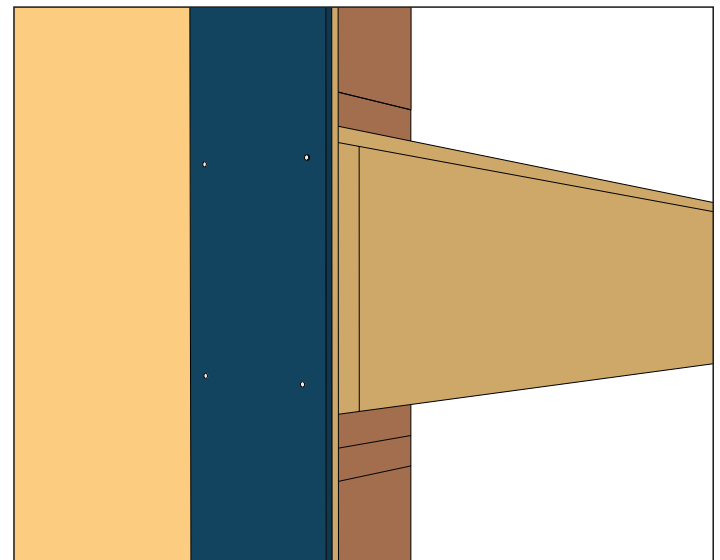
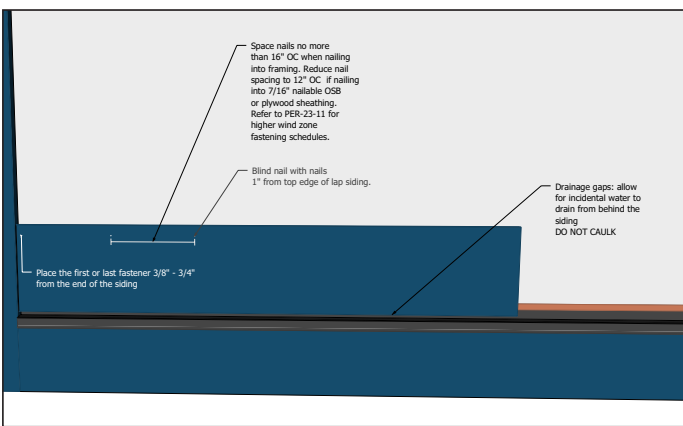

Horizontal trim up to 8" wide fastened to framing requires two fasteners per stud. Wider trim requires three evenly spaced fasteners per stud. Maximum stud spacing cannot exceed 16" OC.

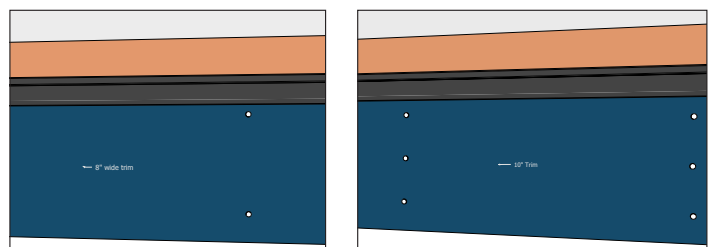
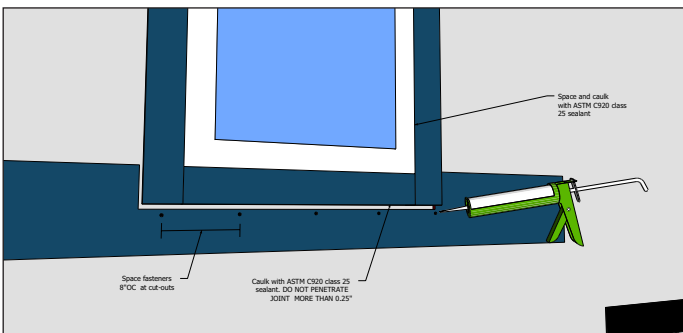

Fasten batten strips, and vertical lap siding with a pair of nails at each end. Place intermediate fasteners at 12" OC along alternating edges. This will result in a single course of fasteners along each edge that are spaced a maximum of 24" OC.

*Fasten Lap siding installed in a slat-wall application using the 8" trim fastening schedule. Flash the top of each piece of siding using the same method described in these instructions for trim.

Fasten panel siding over a nail-able base such as 7/16" OSB or plywood. Flash the top of the panel with z-type corrosion resistant flashing. Cover the edges of joining panels with a corrosion resistant track or batten strip. Install the aluminum track and flashing according to their manufacturer's instructions and local code. Space vertical and horizontal edges 0.25" Add space to account for any flashing or vertical tracks.

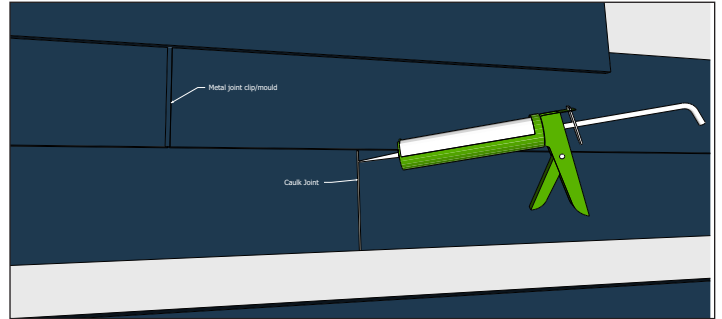
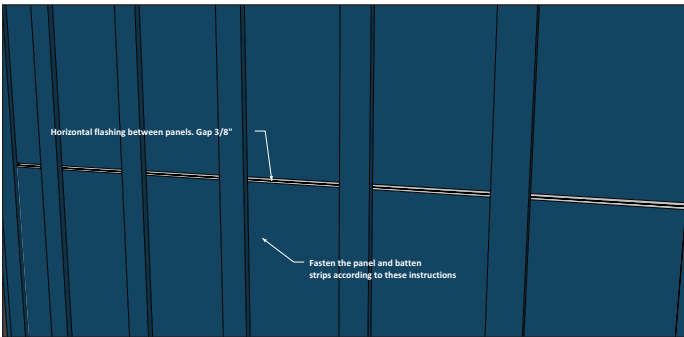
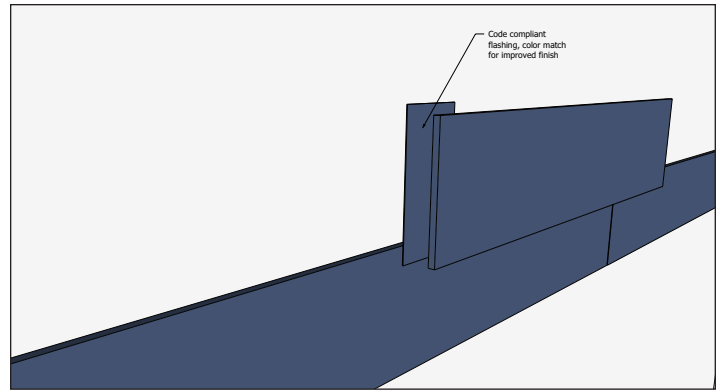
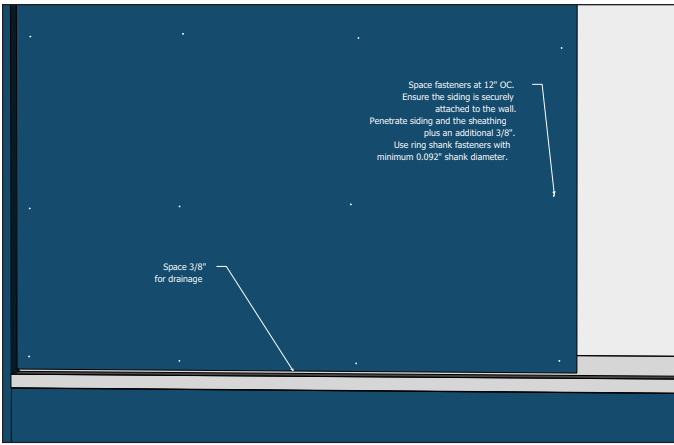

Space butt joints of horizontal lap siding according to the following table.

	20' Long		13' 4" Long	
Below 40°	0.25	1/4"	0.1875	3/16"
Above 40°	0.125	1/8"	0.125	1/8"

Space joints at terminations 1/4" and caulk with class 25 ASTM C920 sealant. This applies for both panel and lap siding. Terminations include vertical trim or other materials adjoining the siding.

Space siding and trim 4" minimum above landscaping and 1/2" minimum above finished surfaces with a water draining slope and protected overhang.

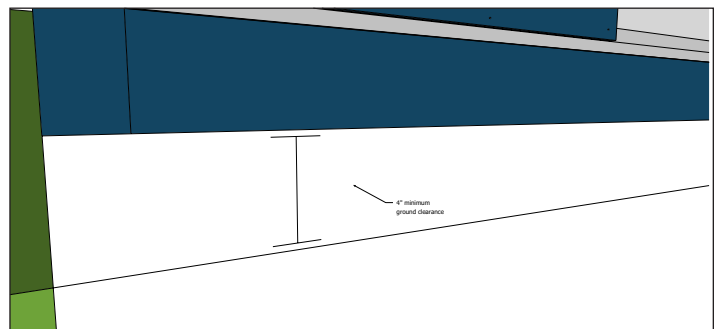
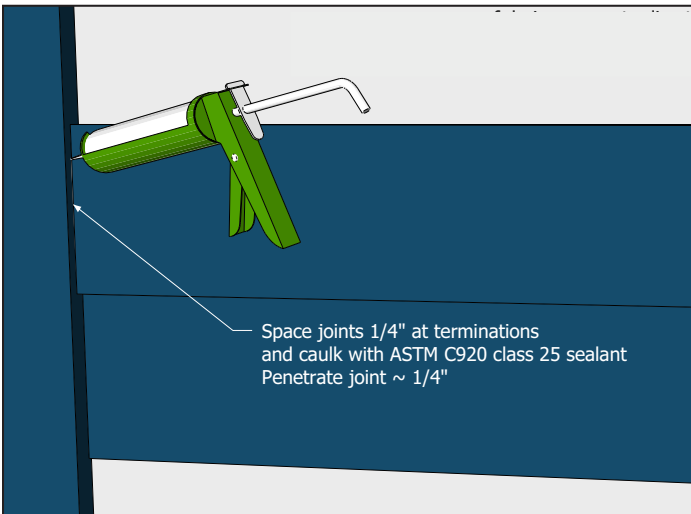

Flash butt joints with a code compliant material to shed moisture to the exterior and protect the house-wrap from direct UV exposure. Paint the ends of the siding thoroughly with a durable exterior acrylic paint. Butt joints may also be caulked with ASTM C920 class 25 sealant or covered with a metal joint clip.

Best practice is 4" minimum ground clearance. Light ground contact is acceptable at sloped draining grades or surfaces where required to meet architectural specifications. Reduced ground clearance or light ground contact will likely increase the frequency for needed coats of maintenance paint. Reduce the potential for paint erosion by directing moisture away from the area with overhangs that include gutters or other drainage systems.

TOUCH-UP AND PAINTING

- Touch-up applicators can be provided to match the finish of the siding. Touch up kits are available for purchase with your siding.
- Porcelain White RISE Trim, and all RISE siding colors can be purchased at your local paint store. Please refer to RISE Paint & Caulk Color Match Chart, or www.risebuildingproducts.com, for current colors.
- If primer touch up is needed, use 100% acrylic exterior primer followed by 100% acrylic exterior paint. It matters little about the solids and such, as long as it is exterior grade, and 100% acrylic (latex is equivalent to acrylic).

CLEANING

- It is recommended to wash RISE Siding and Trim during the hottest and driest time of the summer. This allows for quick drying, which will help avoid mold and mildew growth.
- If dirt or other debris collects on the surface of the siding or trim, wash with a sponge, cloth or light bristle brush – the type of brush that is used on cars. **DO NOT POWER WASH THE SIDING.** Power washing can damage the siding and other wall components.
- Use a light detergent and water mixture as per the detergent manufacturer's directions. Avoid abrasive cleansers.
- Rinse the siding and trim with a garden hose and spray nozzle, or a power washer set to the largest fan setting.
- For stubborn mildew, mix a solution of 1 part bleach to 3 parts water into a garden sprayer attachment and spray the affected areas with the solution.